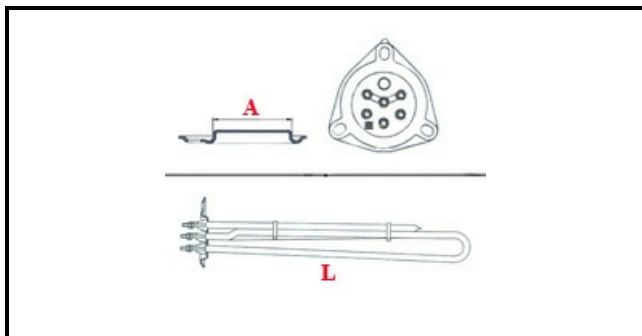

1101286

RESISTENZA 10000W 230/400V CMND

Data: 22-01-2025

ORIGINAL
OSP
SPARE PARTS**Dati tecnici**

LUNGHEZZA MM	L=480mm
NR ELEMENTI	ELEMENTI/ELEMENTS=3
FLANGIA TRIANGOLARE	TRIANGOLARE/TRIANGULAR FLANGE=57mm
DIAMETRO mm	A=57mm
KILOWATT KW	KW=10
WATT	WATT=10000
TRIFASE	TRIFASE/THREEPHASE
NUMERO POLI	POLI/POLES=6
FORI NUMERO	FORI/HOLES=3
GUARNIZIONE	2101033
RESISTENZE PER IMMERSIONE	IMMERSIONE/IMMERSION

Codici produttore

ANGELO PO GRANDI CUCINE SPA
COMENDA - ALI GROUP SRL A SOCIO UNICO
COMENDA - ALI GROUP SRL A SOCIO UNICO
COMENDA - ALI GROUP SRL A SOCIO UNICO
COMENDA - ALI GROUP SRL A SOCIO UNICO