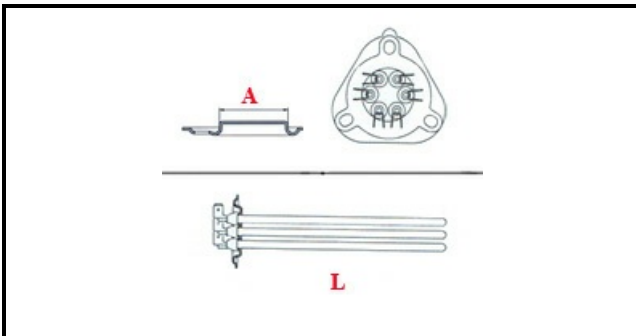

1101547

"RESISTENZA 17000W ; KIT"

Data: 15-11-2024

ORIGINAL
OSP
SPARE PARTS**Dati tecnici**

| | |
|------------------------------|---------------------------------------|
| LUNGHEZZA MM | L=590mm |
| NR ELEMENTI | ELEMENTI/ELEMENTS=3 |
| FLANGIA TRIANGOLARE | TRIANGOLARE/TRIANGULAR FLANGE=47mm |
| DIAMETRO mm | A=47mm |
| KILOWATT KW | KW=17 |
| WATT | WATT=17000 |
| TRIFASE | TRIFASE/THREEPHASE |
| NUMERO POLI | POLI/POLES=6 |
| FORI NUMERO | FORI/HOLES=3 |
| GUARNIZIONE | 2101032 |
| RESISTENZE PER IMMERSIONE | IMMERSIONE/IMMERSION |

Codici produttore

ELECTROLUX PROFESSIONAL S.P.A.

ELECTROLUX PROFESSIONAL S.P.A.